



ME 250 OWNER'S MANUAL

**250W MAX POWER
ELECTRIC Mini Bike**



Read and understand this manual before riding!

Always wear a helmet it could save your life! This Mini Bike is designed for operators age 8 and over. Adult supervision is required for riders age 16 and under!

Provincial/Municipal governments have different regulations pertaining to owning and operating an off-road vehicle, learn the regulations in your area.

www.evoltadventure.com

ME250 Electric Powered Mini Bike

This operator's manual contains important safety information and maintenance information. Read it carefully before using this vehicle. Failing to follow the warnings contained in this operator's manual could result in INJURY or DEATH.

Keep this manual in a safe place. It is very important that this owner's manual be reviewed by any rider and it should remain with the vehicle when transferred to a new owner.

All information images and specifications contained in this manual are based on the latest product information available at the time of publication. Due to improvements or production changes, there could be discrepancies in this manual. E-Volt reserves the right to make product changes at any time, without notice and without obligation to make the same or similar changes to any vehicle previously built or sold

DO NOT OPERATE THIS VEHICLE ON PUBLIC ROADWAYS or any location where there is vehicular traffic. Doing so would be very dangerous and could also be in violation of local traffic laws and restrictions. Always wear a helmet and protective eyewear and clothing.

No part of this owner's manual may be reproduced or copied without express written permission from E-Volt.

Essential Technical Parameters

1. Vehicle

- 1.1 Dry mass (Net Weight):22kg(48lbs);
- 1.2 Gross mass (Gross Weight):25kg(55lbs);
- 1.3 Maximum load(weight): 45kg (100lbs);

2. Motor

- 2.1 Type: DC, with brush;
- 2.2 Rated continuous output power: P=250W;
- 2.3 Rated speed:2750 \pm 7.5%rpm;
- 2.4 Rated voltage:24V;
- 2.5 Rated output torque: 1.21 (N.m)

3. Controls

- 3.1 Rated input voltage:24V;
- 3.2 Input voltage range:20~28V;
- 3.3 Input current without load: \leq 115MA,
- 3.4 Max. output current of the motor: 30 \pm 1A;
- 3.5 Under-voltage protection(Volt): 20 \pm 0.5V;
- 3.6 Max. conduction value: \leq 95% (with the output current of the control $<$ 2A);
- 3.7 Starting voltage of handlebars: \geq 1.4V;
- 3.8 Protection voltage of the handlebars: \leq 1.8V;

4. Charger

- 4.1 Input: 100-240 VAC, frequency 50/60 Hz, input current: 1.8A Max.,
- 4.2 Out put: 24V DC 1.5A

5. Batteries

- 5.1 Size: 151 *65*96(100) mm;
- 5.2 Type: Lead Acid Battery, 2 X 12V ,9AH

CONTENTS

Names of all structural components.....	1
Introduction.....	2
Safety.....	3-5
Initial Setup.....	6-8
Operating Controls.....	9-10
Before You Ride.....	11-12
Basic Operation.....	13-14
2-Stage Safety Speed Limiter.....	15
Maintenance &.....	16-21
Troubleshooting Guide.....	22-23
ME250 Product Registration.....	24

Names of all structural components

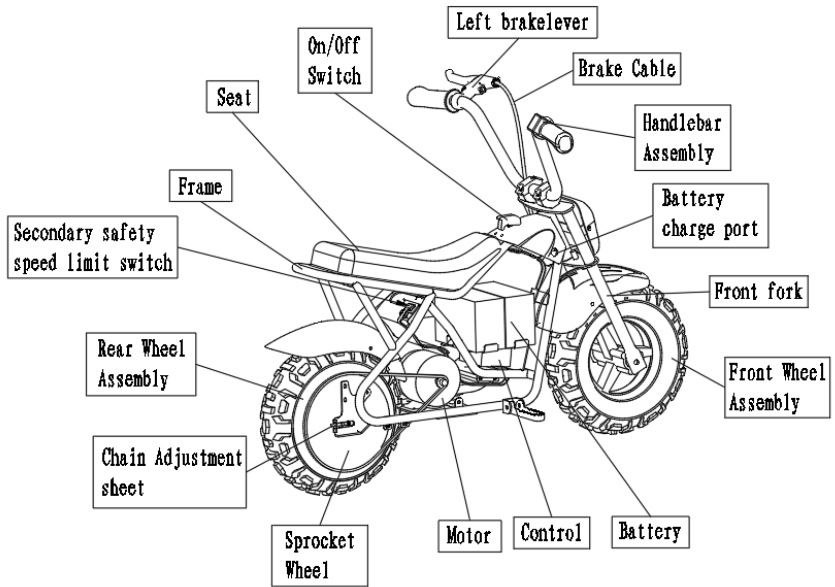

Introduction

Thanks for your choosing the ME250 Electric Powered Mini Bike! The ME250 mini bike was designed as a recreational vehicle for off-road use only and by a single rider only. This mini bike is built for younger riders who are under 100 lbs. with minimal experience

Before riding, please take your time to get acquainted with your mini bike and how it works. To protect your investment, we urge you to keep it well maintained. In addition to regular maintenance, it is important to observe and perform all pre-ride and periodic checks outlined in this manual, where you will also find helpful safety information, instructions and helpful tips. Keep the manual well to refer to later on as questions may come up

As you read through this manual you will find information that is noted with a NOTICE symbol. This is to point out key bits of information that will help you avoid damage to your mini bike and property around you. This manual covers basic maintenance procedures as well

Read the warranty page careful so that you understand your rights and responsibilities

Whenever you ride, tread lightly by staying on established trails and in approved areas. Protect the environment and keep off-road riding areas open for future use.

IMPORTANT SAFETY INFORMATION

Your personal safety and the safety of those around you is our primary concern. Operating this mini bike safely is an important responsibility and should not be taken lightly.

We have provided you with safe operating procedures; warning labels on your mini bike and in this manual. This information will alert you to potential hazards that could harm you or others.

It is understood that it is not practical or possible to warn you about all possible hazards associated with off-road riding and maintaining your mini bike. You must always use your own best judgement.

Safety information is presented in a variety of forms, including:

Safety labels and tags on the mini bike.

Safety messages preceded by a safety symbol  and one of these three signal words: DANGER, WARNING and CAUTION.

 **DANGER**  **WARNING**  **CAUTION**

Any of the above labels can indicate a danger where you or someone around you can be KILLED or SERIOUSLY INJURED if the instructions that it accompanies are not followed carefully.

This manual is filled with important safety information, please read it carefully and be sure that you understand it.

IMPORTANT SAFETY INFORMATION

Safety is our number one priority. There is an inherent level of risk when using any motorized powersports product and an electric mini bike is no different. Read the following warnings carefully to understand how you can avoid injury to yourself, others and your ME250.

RULE NUMBER 1 **⚠DANGER**

READ THIS BOOK COMPLETELY BEFORE RIDING THE FIRST TIME

There is valuable and important information in this user guide that will keep you safe and protect your mini bike from becoming damaged from neglect. Read it carefully and understand the contents. If you have any questions please call the dealer.

RULE NUMBER 2 **⚠DANGER**

PARENTAL SUPERVISION REQUIRED.

An electric power sport product is not a toy. A child can not be left alone to play with this product. Any rider under the age of 8 should not ride this mini bike and all children must have parental supervision when riding. The age of 8 is only an estimate as it is affected by weight, height and riding ability. A parents' decision to allow their child to ride this mini bike should be based on their child's level of maturity and motor skills

RULE NUMBER 3 **⚠DANGER**

RIDE AT YOUR OWN RISK AND USE COMMON SENSE.

Any mishap while using a power sports product can result in serious injury or death Avoid situations where you can't see what is in front of you or behind you, where other traffic is present and/or where your speed is too fast for the conditions. Always ride within your own limitations. Always obey local laws and regulations in your area Do not ride your mini bike where such vehicles are prohibited

RULE NUMBER 4 **⚠DANGER**

NEVER RIDE ON PUBLIC ROADWAYS

This minibike is designed for off-road use only. Never ride in roadways or near any motor vehicles.

RULE NUMBER 5



RIDE SMART

Never attempt to carry a passenger. Keep both hands on the handlebars at all times. Never ride while wearing headphones, earbuds, or while using a cell phone. Keep fingers and other body parts away from moving parts like the drive chain and sprocket as injuries may result. Never attempt to jump off of a ramp or near stairs. Never use near a pool or near spraying water. Always wear proper riding attire including gloves, knee pads, sturdy shoes, a properly fitting DOT approved helmet and goggles. Keep loose clothing and shoelaces away from moving parts like the drive chain and sprockets.

FAILURE TO ADHERE TO THE ABOVE RULES AND CAUTIONS COULD RESULT IN SERIOUS PERSONAL INJURY OR DEATH. USE WITH CAUTION, BE AWARE OF YOUR SURROUNDINGS AND PRACTICE SAFE RIDING TECHNIQUES.

If you have determined that your child is ready to ride please remember the following points:

- Never let your child ride without a helmet
- Your child's safety is your responsibility. Do not take it lightly
- Never push you child to try things before they are ready
- Always supervise your child when they are riding
- Proper maintenance and upkeep of the mini bike is the key to safe riding

 PLEASE NOTE:

Any modifications or improper accessories added to the mini bike with parts that are not manufactured by us can make it unsafe. We strongly recommend that you do not remove any of the original equipment or make any modifications that alter the design and/or operation of the mini bike.



Initial Setup

STEP 1. UNPACK YOUR ME250. The contents are as follows:

1. ME250 Electric Mini Bike
2. Tool Pouch with tools
3. Battery Charger
4. Owner's Manual

Once you have located all of these items, move on to step 2

STEP 2. ASSEMBLE THE HANDLEBARS. Your ME250 arrives almost completely assembled, making it easy to start riding. The only assembly that is required for your ME250 is to attach the adjustable handlebars And front trim pieces. All cables and controls are already hooked up to the bike, so attaching the handlebars is easy

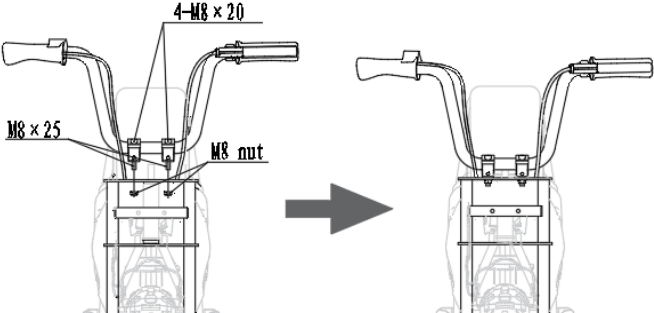
REQUIRED TOOLS	
10-13mm open wrench	6mm Allen key
	
<p>1. Using the 10-13mm open wrench from your tool kit, Put the handlebar mounting bolt (M8×25) into the frame mounting hole and tighten the (M8) nut with a 10-13 open end wrench</p> 	

2. The handlebar Angle can be adjusted. Loosen the 4 M8x20 bolts, adjust the handlebars to a comfortable position, keep the handlebars centered and tighten the bolts.



⚠CAUTION Be careful not to lean the handlebars too far forward or backward as this will affect the bike's handling and comfort of the ride.

3. Install front trim panel

Install the front trim panel to the front fork assembly with M5X14 bolts and tighten the bolts with a Phillips screwdriver.

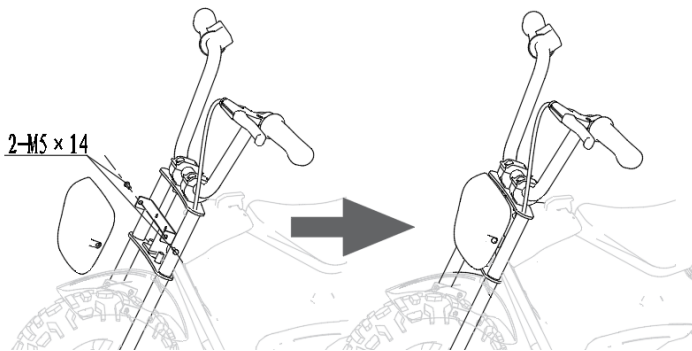

STEP 3 Connect the power

(The ME250 power supply is disconnected during transit for safety reasons)

1. Plug the fuse into the fuse slot of the power cord and close the cover
2. Place the power cable with the fuse in the battery box



STEP 4 CHARGE THE BATTERY

First make sure the power switch is off. The charger interface is located at the lower right of the power switch (as shown in the picture). There are three round contact points in the interface, and the round head of the charger wire has three round holes, which just match the charger interface. Ensure that the charger plug is firmly inserted into the charger interface when charging, and please cover the protective cap when not charging.



Plug the charger into a wall outlet. If the light on the charger does not work, check the electrical outlet. If necessary, try different outlets.

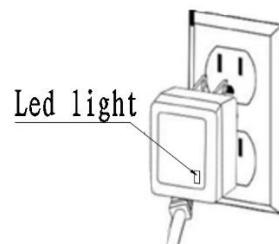

OPERATING CONTROLS

To operate your electric mini bike you need to be able to operate the throttle, brake and other controls without stopping to look at them. Please study the image below carefully to become familiar with the function and the location of each control

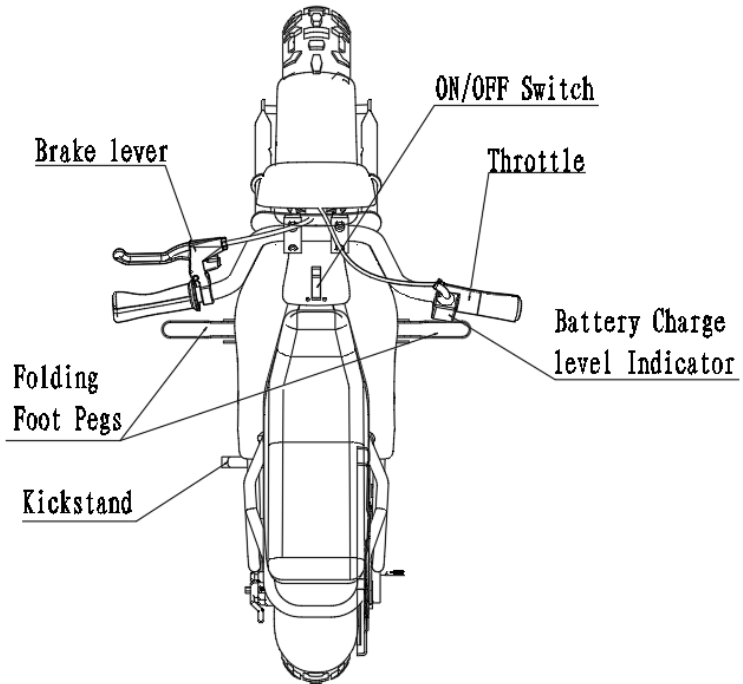

OPERATING CONTROLS

When operating your ME250, there are some key operating controls and components that allow you to operate your mini bike

Their location and operation information is shown below

1. On/Off Switch
2. Throttle
3. Brake

ON/OFF SWITCH

The ON/OFF switch is conveniently located just ahead of the driver and is equipped with a flip-up cover. The cover, when closed also shuts off the On/Off switch. The switch should be left in the off position whenever the bike is not being used to protect the charge that is in the battery.



THROTTLE

The throttle provides the power for the car to move forward, and because of the rotating throttle structure, the power and speed are variable.

⚠ DANGER When giving the throttle power, twist it slowly at first to avoid sudden acceleration



BRAKE

The ME250 is equipped with a rear disc brake. The brake lever is hand operated and is on the left hand grip mounted to the handlebars. Squeeze the brake carefully with increasing force to stop the bike

⚠ DANGER Applying the brakes too quickly can cause the bike to skid and you may lose control



BEFORE YOU RIDE

Once your bike has been allowed to charge fully, disconnect the battery charger from the bike and from the wall plug, and store it in a safe place

Check list before riding

1. Have you completely read and do you thoroughly understand this owner's manual?
2. Have you found all the safety messages on your mini bike and do you understand them?
3. Do you understand the location of, and how all the operating controls on your mini bike work?
4. Are you in good mental and physical condition?
5. Are you drug and alcohol free?
6. Are you wearing a DOT-approved helmet that fits properly?
7. Are you wearing eye protection?
8. Are you wearing sturdy shoes and protective clothing?

Additional suggested protective clothing.

1. Gloves to protect your hands
2. Sturdy riding boots that support your ankles
3. Riding pants with knee and hip pads
4. Riding jersey with elbow pads and chest/shoulder protection

As a reminder:

⚠ DANGER Never let your child ride without a helmet. Helmets significantly reduce the number and severity of head injuries. An approved DOT motorcycle helmet is the most important part of your safety gear. Choose one that fits properly and is snug on your head. Motorcycle dealers can help in selecting a good quality helmet with proper fit.

Before you ride

You must be certain that you and your mini bike are ready to ride. Below is the pre-ride checklist. Be sure to review all the topics every time before riding

PRE-RIDE INSPECTION

1. Check tire pressure with the tire gauge in your ME250 tool kit. Be sure they are at 15-20 psi.
2. Check rims to make sure they are not bent or damaged.
3. Check the level of charge on the batteries.
4. Check the drive chain to see if it needs to be lubed or tightened.
5. Check the brake to be sure it is working properly.
6. Look over the entire bike for loose nuts and bolts or body parts.
7. Check the throttle to be sure it rotates freely and returns to the low position on its own when released.
8. Be sure that the handlebars turn freely.

⚠DANGER Failure to properly maintain your mini bike can lead to a crash in which you can be seriously injured or killed. Always perform a pre-ride inspection on your mini bike and keep it in good condition to get the most out of your ME250 electric mini bike.

BASIC OPERATION

The ME250 has a 250 Watt motor and 24 volts of electrical power. It is very important not to underestimate the ME250. Avoid getting injured.

STEP ONE: TURN THE POWER ON

This bike is equipped with a main toggle switch that is within easy access of the rider. This switch cuts off all power to the motor. To turn the switch on, flip up the toggle cover and push the switch forward, or to the ON position.

You will see the battery charge indicator lights on the throttle twist grip light up, indicating how much charge is available.

⚠ DANGER NEVER TURN THE ACCELERATOR TWIST GRIP WHEN THE UNIT IS ON AND YOU ARE NOT SITTING ON IT. THE MINIBIKE CAN LURCH FORWARD CREATING A HAZARDOUS SITUATION.

To turn the switch off, you can move it backward, to the OFF position. Or, you will notice that by closing the toggle cover, the switch is automatically moved to the OFF position.

STEP TWO: ACCELERATE SLOWLY

With the switch in the ON position and sitting on the minibike, put both hands on the handle grips with both feet on the ground. Very gradually, turn the inside portion of the right-hand grip downward. You will feel the bike start to move forward. As you gain speed, you will be able to put both feet on the foot pegs and ride.

STEP THREE: BRAKING

This bike is equipped with a rear disc brake. To use the brake, gently squeeze the brake handle until the brake takes effect. Carefully apply the brake while moving as jamming on the brakes too quickly can cause you to go into a skid and lose control.

BASIC OPERATION

STEP FOUR: STOPPING AND PARKING

It is always best to park the minibike on a smooth, level surface to avoid damage from accidental tip-overs. Flip down the kickstand (located on the bottom of the frame on the left side) to rest the bike on. Turn the switch to the OFF position and flip down the toggle cover

NOTE: IT IS VERY IMPORTANT TO STORE YOUR ME250 INSIDE, OUT OF THE WEATHER. THE ELECTRICAL SYSTEM IS COVERED BUT SHOULD NOT BE EXPECTED TO BE TOTALLY WATER TIGHT AND WATER DAMAGE CAN OCCUR IF LEFT OUT IN WEATHER

SHENGQI WILL VOID THE WARRANTY, IF PRODUCT HAS NOT BEEN PROPERLY STORED

2-Stage Safety Speed Limiter

The ME250 electric minibike is equipped with a special switch, Adjust speed to suit younger, smaller riders. The switch is located in the battery case under the seat cushion, a hard-to-reach area to restrict access for curious younger children.

NOTE: THE 2-STAGE SAFETY SPEED LIMITER SWITCH IS SET AT THE FACTORY TO THE SLOWER SPEED. To switch from slow speed to regular speed, or vice-versa, follow the steps below

1. Move the switch to your desired position. "O" for regular speed and "I" for slow speed.
2. The mini bike has a top speed of 9.5mph and a slow speed of 5.5mph

9.5 MPH min (Slow Speed)

5.5 MPH min (Slow Speed)



MAINTAINING YOUR MINI BIKE

Being an electric-powered vehicle, your ME250 is a relatively low maintenance machine. However, it is important to properly care for the unit to keep it operating properly and safely. Below are items that you will need to care for on a regular basis

STORE INSIDE OUT OF THE WEATHER

▲WARNING IT IS CRITICALLY IMPORTANT TO ALWAYS STORE YOUR ME250 INDOORS AND OUT OF THE WEATHER. THE ELECTRICAL SYSTEM IS COVERED BUT SHOULD NOT BE CONSIDERED SEALED WATER CAN CAUSE SERIOUS DAMAGE TO THE POWER TRAIN AND CREATE A DANGEROUS SITUATION. WATER DAMAGE WILL VOID YOUR WARRANTY

DRIVE CHAIN TENSION

The drive chain transmits power from the motor to the rear wheel. To work properly it must be lubricated and properly tensioned at all times Check the tension on the drive chain by moving it up and down approximately halfway between the sprockets. There should be no more than 1/2" vertical slack in the chain. If the chain seems too loose, it may be in danger of coming off while riding

To adjust the chain tension, follow the steps outlined below:

1. Be sure that the minibike is parked on a flat, level surface and leaning on the kickstand
2. Using a 16mm wrench, loosen the rear wheel axle nuts on each side.
3. After the axle nuts are loosened, use a 10mm wrench to turn the sprocket side tensioner bolt clockwise (to tighten) about one turn, then repeat this process on the other side tensioner bolt.
4. Check the tension on the chain and see if it has changed enough. If not, repeat steps 3 & 4 until the proper tension is achieved



MAINTENANCE

DRIVE CHAIN TENSION (CONTINUED)

5. Tighten the axle nuts securely to 35-47 N.M.

NOTE: To loosen the chain tension, follow the steps above except turn the tensioner bolts counter-clockwise (outward) to loosen

LUBRICATING THE DRIVE CHAIN

The drive chain on your ME250 must be kept lubricated often to avoid excessive wear. To lubricate the drive chain, follow the steps below:

1. Park the bike on a level, flat surface using the kickstand
2. Lean the bike toward the kickstand so that the rear wheel comes off the ground an inch or two.
3. As you rotate the rear tire, wipe down the chain with a clean cloth to remove as much grime and build up as possible
4. Again rotating the rear tire, spray a good chain lubricant on the chain so that the full length of the chain is lubricated. Use any spray lube, a household oil like 3-in-1 oil, or any bicycle-specific chain lube. Spray solvents like WD-40 are not recommended as they tend to dilute and remove oil from the chains.

NOTE: The chain should be thoroughly lubricated but without buildup of lube, which can collect dirt and grit which causes damage to the chain.

REPLACING THE FUSE

The bike is equipped with a 40-amp fuse to protect the system in the event of electrical shorts. When a short or overload in the system occurs, the fuse activates which will protect the wiring and help to avoid possible fire

Possible situations that can result in a blown fuse can be

1. A worn or pinched wire in the system that causes a short
2. Moisture in the system
3. Overloaded electrical system

MAINTENANCE

In the event of a burned-out fuse, your ME250 will not work when you turn it on and the indicator lights will not light up. To check and/or replace the fuse, follow the steps on the following page:

1. Open the plastic battery case by removing both knob screws (on the front and back of the battery case) and pulling the right side panel off
2. Locate the black rubber fuse housing, in the wiring above the battery
3. Open the rubber flip top lid and carefully pull out the fuse
4. Inspect the fuse and replace if necessary
5. Re-assemble the fuse holder and the battery case, making sure it is clean and dry inside and that all the wiring is safely tucked inside.
Watch carefully for pinched wires

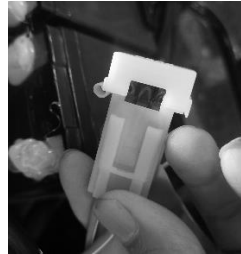
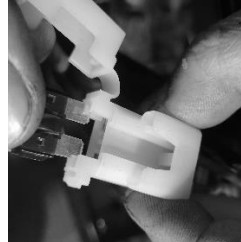

NOTE: IF THE FUSE CONTINUES TO BURN OUT YOU HAVE ENCOUNTERED AN ELECTRICAL PROBLEM

ADJUSTING THE BRAKE

This bike is equipped with a rear disc brake system. You should check the brake and make sure it is working properly before each ride. The brake should feel firm when the lever is pulled and you should not be able to pull the brake lever all the way back to where it touches the hand grip. If you can squeeze the brake lever all the way to the hand grip, your brake needs adjusting. There are two options to adjust the brakes.

OPTION 1: Adjust using the barrel roller.

1. Loosen the set ring on the barrel adjuster
2. Screw the barrel adjuster out a few turns and then check the tension in the lever
3. If it feels right, re-tighten the set ring

MAINTENANCE

4. If not, repeat step 2 until the brake feels right and then tighten the set ring nut

ADJUSTING THE BRAKE (CONTINUED)

OPTION2: Adjust using the actuator arm on the brake caliper.

If you are not able to get enough adjustment using the barrel adjuster, you may need to adjust the brake using the actuator arm on the rear caliper.

1. Locate the rear brake actuator arm where the brake cable is connected to the rear brake caliper.
2. Using a 6mm Allen key, loosen the brake cable nut that secures the cable to the actuator arm so that the cable can slide freely through the bolt
3. Slide the actuator arm forward until it stops, then back it off about a half of an inch, making sure the cable slides freely through the bolt
4. Holding the actuator arm in position, carefully re-tighten the cable bolt until it is snug.
5. Check the brakes and make sure they work properly



NOTE: Be sure the brake is not TOO TIGHT, which will impede performance and cause excessive wear on the brake.

MAINTENANCE

CHECK THE TIRE PRESSURE

It is very important to check the tire pressure before every ride. Running on low tire pressure can create a dangerous situation as the bike will not handle properly and could cause the rider to lose control. To check the tire pressure, locate the air stems inside the rims on each wheel and remove the black plastic cap. Using a tire gauge, check to make sure that there is at least 15, and no more than 20lbs of pressure in each tire



REMOVING THE BATTERIES

The two batteries on your ME250 are removable and replaceable. To remove the batteries, follow the steps outlined below:

1. Open the plastic battery case by removing both knob screws (on the front and back of the case) and pulling the right side panel off.
 2. Unhook the rubber strap that holds the batteries in place
 3. Slide the batteries partially out of the holder one at a time, removing the terminals by pulling them off. Remove the negative terminal first
- WARNING** BE CAREFUL NOT TO TOUCH THE NEGATIVE CABLE TO THE CONNECTED POSITIVE CABLE AS IT MAY SPARK AND/OR CAUSE A FIRE
4. Once the cables are disconnected from the terminals, slide the batteries out

MAINTENANCE

WARNING THE ME250 USES LEAD ACID BATTERIES WHICH MUST BE DISPOSED OF PROPERLY DROP THEM OFF AT ANY LOCATION THAT SELLS AUTOMOTIVE BATTERIES. DO NOT DISPOSE THEM IN YOUR HOUSEHOLD TRASH AND NEVER BURN A LEAD ACID BATTERY AS AN EXPLOSION COULD OCCUR

WARNING IF A BATTERY LEAK OCCURS, AVOID CONTACT WITH THE ACID AS IT IS CORROSIVE, POISONOUS AND DANGEROUS. IF ACID COMES INTO CONTACT WITH SKIN OR EYES, FLUSH WITH COOL WATER FOR AT LEAST 15 MINUTES AND SEE A PHYSICIAN IMMEDIATELY

WARNING DO NOT MIX OLD AND NEW BATTERIES. DO NOT MIX ALKALINE, STANDARD OR RECHARGEABLE BATTERIES TOGETHER, AND ONLY USE SHENGQI SPECIFIED BATTERIES.

TROUBLESHOOTING GUIDE**TROUBLESHOOTING GUIDE**

PROBLEM	POSSIBLE CAUSE	SOLUTION
Does not run	Undercharged battery or loose connection	Charge the battery for at least 12 hours before using the first time If the bike has been used before, charge for at least 8 hours Check all battery connections and tighten as needed Check the fuse. Replace if blown following the instructions on pages 17 and 18 of this book Make sure wall outlet where charger is plugged in is working.
Bike was running but Stopped abruptly	Blown fuse Power switch damaged	Allow the motor to cool off for 20 minutes and then replace the fuse following the instructions on pages 17 and 18 of this book.
Lack of power	Brake too tight The battery is undercharged The type is underinflated Battery will not accept a full charge and needs to be replaced The terrain is uneven The bike is overloaded	Adjust brake per instructions on pages 19 of this book Charge battery at least 8 hours Inflate tires per instructions on page 20 of this book Use on smoother, more level surfaces Do not exceed 100lbs.of rider weight Do not attempt to carry passengers.

TROUBLESHOOTING GUIDE**TROUBLESHOOTING GUIDE**

PROBLEM	POSSIBLE CAUSE	SOLUTION
Charger gets warm when in use	Normal	No action is required. The charger will generate a small amount of heat as the battery is charging
Bike does not stop	Brake out of adjustment	Adjust brake per instructions on pages 19 of this book
Bike makes a grinding or squeaking noise when moving	Chain needs adjustment and lubrication	Lubricate the chain per the instructions in the maintenance section of this book
Bike runs fine but seems too slow	Slow Speed Safety Switch is on	Refer to the Slow Speed Safety Switch section on page 14 in this book to change the switch to regular speed

WARNING

THIS IS SPORTING EQUIPMENT AND NOT A TOY FOR YOUNGER CHILDREN USING THIS PRODUCT MAY BE A DANGEROUS ACTIVITY AND MAY RESULT IN INJURY OR DEATH EVEN WHEN USED WITH PROPER SAFETY PRECAUTIONS. USE AT YOUR OWN RISK.

www.evoltadventure.com

EVOLT



COPYRIGHT © E-VOLT. ALL INFORMATION CONTAINED WITHIN THIS PUBLICATION IS BASED UPON THE LATEST PRODUCT SPECIFICATIONS AND INFORMATION AT THE TIME OF PUBLICATION. BECAUSE OF THE CONSTANT ENHANCEMENT IN THE QUALITY AND DESIGN OF PRODUCTION COMPONENTS, DISCREPANCIES MAY VARY BETWEEN THE ACTUAL VEHICLE AND THE INFORMATION PRESENTED IN THIS PUBLICATION. NO LIABILITY CAN BE ACCEPTED FOR OMISSIONS OR INACCURACIES. ANY REPRINTING OR REPRODUCTION, WHETHER WHOLE OR IN PART OF THIS PUBLICATION IS STRICTLY PROHIBITED.

Version: 10012201