

Assembly Instructions

⚠ WARNING

Never Attempt to start this Go-Kart without reading and understanding the Owner's/Operator's manual. The Owner's/Operator's manual provides information on safety, parts, functions, pre-ride inspection, starting and maintenance.



PLEASE NOTE THAT THIS IS NOT THE OWNER'S MANUAL BUT THE ASSEMBLY INSTRUCTIONS ONLY.

BEFORE OPERATING THIS GO-KART, MAKE SURE THE OPERATOR READS AND UNDERSTANDS THE OWNER'S MANUAL, WARNING LABELS AND IS FAMILIAR WITH ALL GO-KART CONTROLS.

PRE-RIDE INSPECTION

Inspecting and checking the condition of the Go Kart before each ride is important. Following the pre-ride check list will help insure the you do not have mechanical problems which could result in injury or becoming stranded. Make sure the Go Kart is in good operating condition before each ride.

⚠ WARNING

Failing to inspect and maintain your Go Kart could be hazardous.

Not following the pre-ride inspection procedures could result in loosing control of the Go Kart resulting in an accident or damage to the Go Kart

Always perform a Pre-ride inspection before each ride.

⚠ WARNING

Performing maintenance and checks while the engine is running could be hazardous.

You could be severely injured by moving parts or hot surfaces.

Never perform maintenance or check procedures while the engine is running with the exception of checking the ignition switch or throttle.

WHAT TO CHECK	CHECK FOR
Steering	<ul style="list-style-type: none"> • Smoothness • No restriction of movement
Brakes	<ul style="list-style-type: none"> • Stops Kart • Inspect hoses • Correct fluid level • Inspect brake pads for wear.
Tires	<ul style="list-style-type: none"> • Proper tire pressure • Proper tread depth • Rubber has no cracks
Fuel Tank	<ul style="list-style-type: none"> • Enough fuel for the ride • Fuel cap secure • Hoses have no signs of cracks or leaks
Throttle Pedal	<ul style="list-style-type: none"> • Pedal snaps back to idle when released • Operates freely
Engine Ignition switch	<ul style="list-style-type: none"> • Switch shuts off engine when
Engine Oil	<ul style="list-style-type: none"> • Correct oil level
Safety Net	<ul style="list-style-type: none"> • Securely attached • Good condition
Drive Chain	<ul style="list-style-type: none"> • Proper tension • Lubricated • No excessive wear or damage
General Condition	<ul style="list-style-type: none"> • All nuts and bolts tight • No rattles from engine or frame while running

SHOCKS ASSEMBLY

M8 X 40 bolt
M8 Lock Nut
M8 Washer

3 ea. (A)
3 ea. (B)
2 ea. (C)

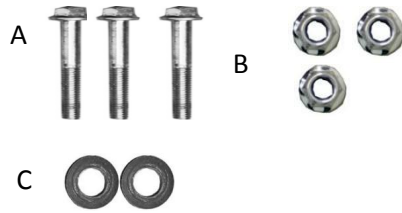

1. Install front shock up side bolt, put the parts like the following order: M8X40 bolt, M8 washer, shock, Frame bracket, M8 lock nut.

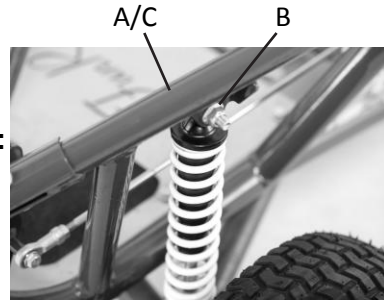

2. Install rear shock up side bolt to kart frame with M8*40bolt and M8 lock nut.

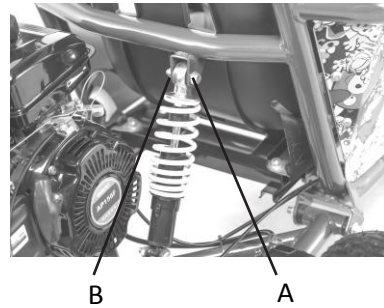

PARTS

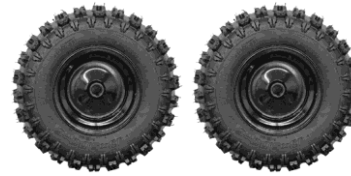

Rear Wheels

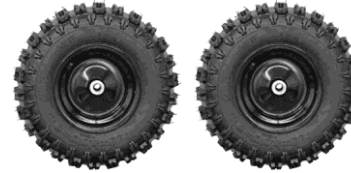

Front Wheels



Hardware



Nose Piece



Safety Net



Net Supports



FRONT BUMPER



Tool Kit

FRONT WHEEL ASSEMBLY

Hardware:

M14 Washer 2ea. (A)
M14 Lock Nut 2ea. (B)



1. Locate front wheels.

Note: Front wheels have bearings on both sides of hubs

2. Install front tires on axles making sure air stem on rim faces out.

3. Attach wheel to axle using hardware in the following order:

Washer (A)
Lock Nut (B)

Tighten lock nut (B) snug. Do not over tighten.

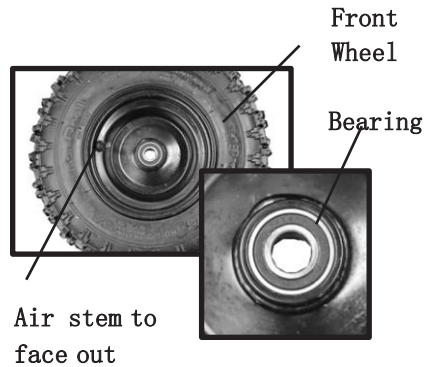

⚠ WARNING

Failing to install cotter pins could be hazardous.
Failing to install cotter pins could cause the wheel to fall off resulting in an accident.
Never operate Go Kart without cotter pins installed

NET SUPPORT ASSEMBLY

M8 X 45 Allen Head bolts 4 ea. (A)
M8 Lock nut 1ea. (B)
Net 1ea (C)
Loop support 1ea. (D)

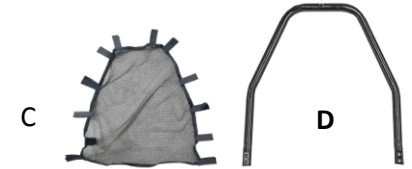

1. Install net to frame using buckles provided .

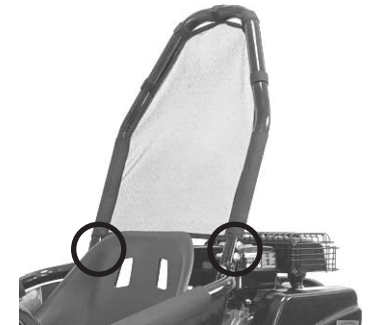

2. Attach Loop Support(D) to kart frame With M8*45.

STEERING COLUMN AND SIDE PADS INSTALL

M8 X 35 bolt 1 ea. (A)
 M8 Lock Nut 1 ea. (B)

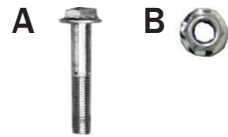

1. Attach steering wheel with Bolt and Nut(C)

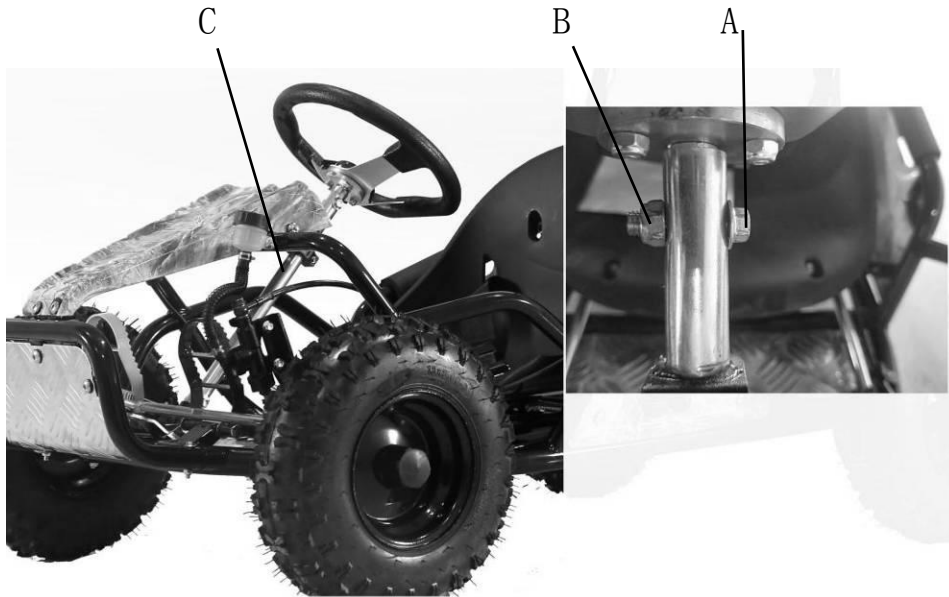

REAR WHEEL ASSEMBLY

Hardware:

Wheel Spacers 2ea. (A)
 Key 2ea. (B)
 M14 Lock nuts 2ea. (C)

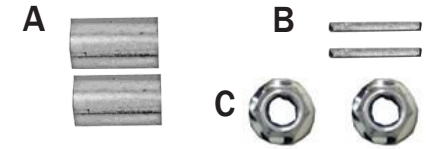

1. Slide wheel spacer (A) over axle
2. Insert Key (B) into Key way groove on axle.
3. Install Tires on rear axle making sure air stem on rim faces out.
4. Attach wheel to axle using the M14 Lock nut (C)
5. Tighten lock nut (C) snug. Do not over tighten.

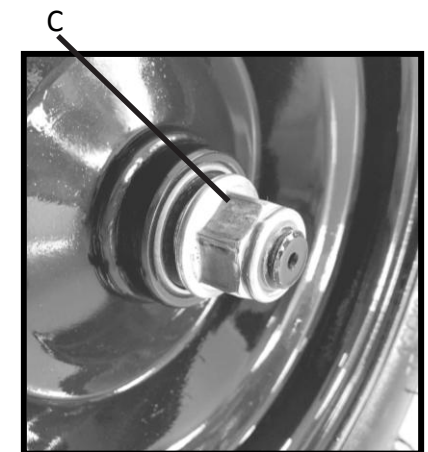
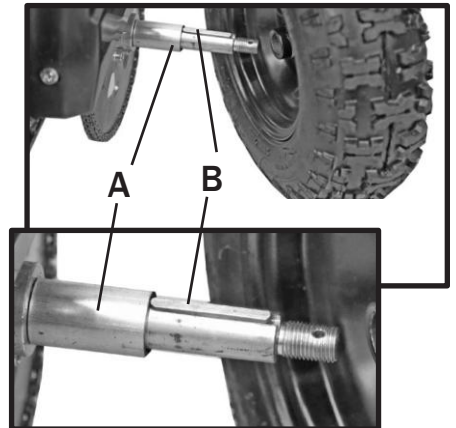
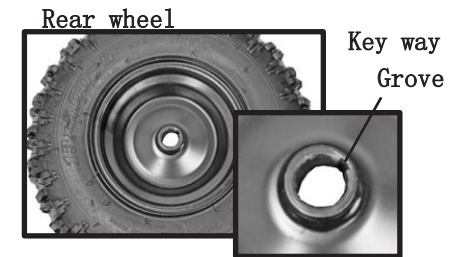

⚠ WARNING

Failing to install cotter pins could be hazardous.
 Failing to install cotter pins could cause the wheel to fall off resulting in an accident.
 Never operate Go Kart without cotter pins installed

BUMPER ASSEMBLY

Hardware:

M8 x 45 bolts 2ea. (A)

M8 Lock Nuts 2ea. (B)

Bumper 1ea. (C)

1. Install front bumper (C) and attach to Frame using bolts (A) and Lock Nuts (B).

Tighten bolts.

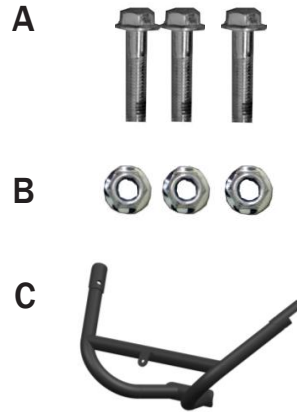

NOSE ASSEMBLY

M6 X 16 Screws 4 ea. (A)

M6 Plastic Flat Washers 4 ea. (B)

Plastic Nose piece 1ea. (C)

1. Attach front nose piece (C) to frame with Screws (A) and plastic washers (B).

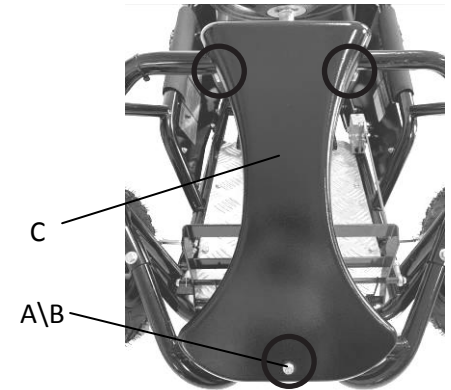
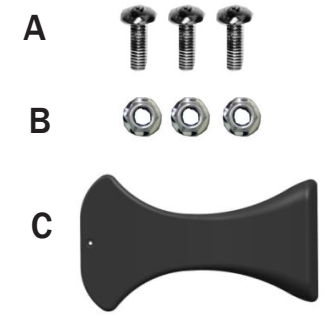

2. Attach wires (D) to ON/OFF switch (E). Note: Colored wires can attach to either terminal.

