

# Electric Mini Motorcycle



## OWNER'S MANUAL

Read and understand this entire manual before using!

NOTE: Manual illustrations are for demonstration purposes only.

Illustrations may not reflect exact appearance of actual product.  
Specifications subject to change without notice.

**OFF ROAD USE ONLY!!!**

**NEVER OPERATE THIS VEHICLE IF YOU ARE UNDER  
AGE 13!!!**

## **INTRODUCTION**

Thank you for purchasing this product. The proper care and maintenance that your vehicle requires is outlined in this manual. Following these instructions will ensure a long trouble-free operating life of this vehicle and your satisfaction with it.

The owner's manual corresponded to the latest state of this vehicle at the time of printing. Slight deviations resulting from continuing development and design can, however, not be completely excluded. All specifications are non-binding, we reserve the right to modify or delete technical specification, parts, design, etc... without prior notice.

## **SAFETY WARNINGS**

This vehicle is NOT A TOY and ONLY used in closed off areas remote from public road traffic.

Never permit children under age **13** to operate this vehicle.

Adult's supervision is required if children under age **16**.

### **WARNING:**

Riding this vehicle can be a hazardous activity. Certain conditions may cause the equipment to fail without fault of the manufacturer. Like other vehicles, the Mini Dirt Bike can and is intended to move, and it is therefore possible to lose control, fall off and/or get into dangerous situations that no amount of care, instruction or expertise can eliminate. If such things occur you can be seriously injured or die, even when using safety equipment and other precautions. **RIDE AT YOUR OWN RISK AND USE COMMON SENSE.**

This manual contains many warnings and cautions concerning the consequences of failing to maintain, inspect or properly use your mini dirt bike. Because any incident can result in serious injury or even death, we do not repeat the warning of possible serious injury or death each time such a possibility is mentioned.

## **APPROPRIATE RIDER USE AND PARENTAL SUPERVISION**

This manual contains important safety information and use tips to help you and your child operate and handle the mini dirt bike. Carefully read the manual in its entirety together with your child before letting your child ride it for first time. The manual also contains important information on servicing the vehicle.

It is your responsibility to review the manual and make sure that all riders understand all warnings, cautions, instructions and safety topics and assure that the riders are able to safely and responsibly use this product and protect your child from injury. We recommend that you periodically review and reinforce the information in this manual with your child, and that you inspect and maintain your children's vehicle to insure their safety. **The recommended rider age of 13 years** is only an estimate, and can be affected by the rider's size, weight or skills. Any rider unable to fit comfortably on this vehicle should not attempt to ride it.

**It is important and necessary to conduct the technical training for your child before first use. To get the training information, please contact the dealer who you purchase the vehicle from. Before your child complete the training, do not let your child use this vehicle.**

Children often underestimate or fail to recognize the dangerous situation, you should make it clear to your child that should not, under any circumstances, operate the vehicle without supervision and that your child may only drive at speed that are commensurate with the child's riding ability and other road condition.

**A parent's decision to allow his or her child to ride this vehicle should be based on the child's maturity, skill and ability to follow rules.**

Keep this product away from small children younger than age **13** and remember that this product is intended for use only by persons who are, at a minimum, completely comfortable and competent while operating the vehicle

Do not exceed **145lbs ( 65kgs)** total weight on this vehicle. Rider weight does not necessarily mean a person's size is appropriate to fit or maintain control of this vehicle.

Do not touch the brakes or motor on your bike when in use as they can become very hot.

## **ACCEPTABLE RIDING PRACTICES AND CONDITIONS**

**Always check and obey any local laws or regulations which may affect the locations where the vehicle may be used.**

Ride defensively. Watch out for potential objects that could catch your heel or force you to swerve suddenly or lose control. Be careful to avoid pedestrians, skaters, skateboards, scooters, bikes, children or animals who may enter your path, and respect the rights and property of others.

This vehicle is meant to be used only in controlled environments free of potential traffic hazards and not on public streets or sidewalks. Do not ride your vehicle in any areas where pedestrians or product traffic is present.

Do not activate the speed control on the hand grip unless you are on the vehicle and in a safe, outdoor environment suitable for riding.

The vehicle was manufactured for performance and durability but are not impervious to damage. Jumping or other aggressive riding can over-stress and damage any product, including this vehicle, and the rider assumes all risks associated with high-stress activity. Be careful and know your limitations. Risk of injury increased as the degree of riding difficulty increases. The rider assumes all risk associated with aggressive riding activities.

Maintain a hold on the handlebars at all times.

Never carry passengers or allow more than one person at a time to ride the vehicle.

Never use near steps or swimming pools.

Keep your fingers and other body parts away from the drive chain, steering system, wheels and all other moving components.

Never use headphones or a cell phone when riding.

Never hitch a ride with another vehicle.

Do not ride the vehicle in wet or icy weather and never immerse the vehicle in a water, as the electrical and drive components could be damaged by water or create other possibly unsafe conditions.

The vehicle is intended for use on flat, level ground without loose debris such as rocks or gravel. Wet, slick, bumpy, uneven or rough surfaces may impair traction and contribute to

possible accidents. Do not ride the vehicle in mud, ice, puddles or water. Avoid excessive speed that can be associated with downhill rides. Never risk damaging surfaced such as a carpet or flooring by use of the vehicle in doors.

Do not ride at night or when visibility is limited.

### **PROPER RIDING ATTIRE**

Always wear proper protective equipment such as an approved safety helmet, elbow pads and kneepads. A helmet may be legally required by local law or regulation in your area. A long-sleeved shirt, long pants and gloves are recommended. Always wear athletic shoes, never drive barefooted or in sandals, and keep shoelaces tied and out of the way of the wheels, motor and drive system.

### **USING THE CHARGER**

The charger supplier with the vehicle should be regularly examined for damage to the cord, plug, enclosure and other parts, and in the event of such a damage, the bike must not be charged until the charger has been repaired or replaced.

Use only with the recommended charger.

Use caution when charging.

The charger is not a toy. Charger should be operated by an adult.

Do not operate charger near flammable materials.

Unplug charger and disconnect from bike when not in use.

Always disconnect from the charger prior to wiping down and cleaning the vehicle with liquid.

**FAILURE TO USE COMMON SENSE AND HEED THE ABOVE WARNINGS INCREASES RISK OF SERIOUS INJURY. USE WITH APPROPRIATE CAUTION AND SERIOUS ATTENTION TO SAFE OPERATION.**

### **LOCATION OF WARNING STICKER**

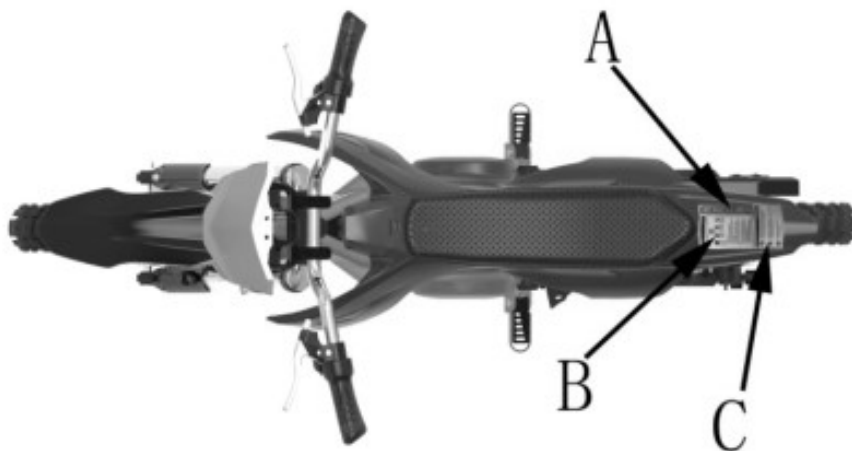

### Sticker A



### Sticker B

**WARNING**

Improper use of ATVs can cause SEVERE INJURY OF DEATH

ALWAYS USE AN APPROVED HELMET AND PROTECTIVE GEAR. NEVER USE ON PUBLIC ROADS. NEVER CARRY PASSENGERS. NEVER USE WITH DRUGS OR ALCOHOL.

**NEVER** operate:

- without proper training or instruction
- at speeds too fast for your skills or the conditions on public roads – a collision can occur with another vehicle
- with a passenger – passengers affect balance and steering and increase risk of losing control

Always:

- use proper riding techniques to avoid vehicle overturns on hills and rough terrain and in turns.
- avoid paved surfaces – pavement may seriously affect handling and control.

LOCATE AND READ OWNER'S MANUAL.  
FOLLOW ALL INSTRUCTIONS AND WARNINGS.

### Sticker C

**WARNING**

**13+** **NEVER** operate this vehicle if you are under age 13. Adult supervision and instruction is required to operate this vehicle if you are under age 16.

 **NEVER** ride as a passenger. Passengers can cause a loss of control, resulting in SEVERE INJURY or DEATH.

 **NEVER** use on public roads. OFFROAD use only.

## TECHNICAL SPECIFICATION SHEET

Motor type	1000W 36V neodymium magnet DC motor
Max. Power output	1.80kw/1600rpm
Rated torque	10.40 N.m
Battery	3x12V9Ah lead acid battery
Optional	36V13Ah lithium battery
Charger for lead acid battery	43.2 V- 1.5A
Charger for lithium battery	42.0V - 2A
Non-load input current	≤115mA
Maximum motor current controller output	35A±1.0A
Transmission	Chain drive
Front suspension	Hydraulic inverted fork
Rear suspension	mono shock absorber
Tyre	front 2.75-12"/ rear 3.00-10" ,with 7.00 P.s.i operation pressure and 36 P.s.i Max. inflate
Brake system	front and rear disc brake with mechanical control
Rated loading capacity	65KG
Max. speed	28KM/hour
Range per charge (lead acid battery 9Ah )	9Km
Range per charge ( lithium battery 13Ah)	16Km
Dry Weight ( lead acid / lithium battery )	42kgs / 36kgs
Dimension (mm)	1330*640*865
Seat height (mm)	620
Min. Ground Clearance(mm)	250
Wheelbase (mm)	920

## PIN LOCATION



PIN is stamp marked on an aluminum plate that is riveted on the steering column .  
**PIN means the Product Identify Number which is unique for each unit.**

### 3-FUNCTION ADJUSTABLE SWITCH

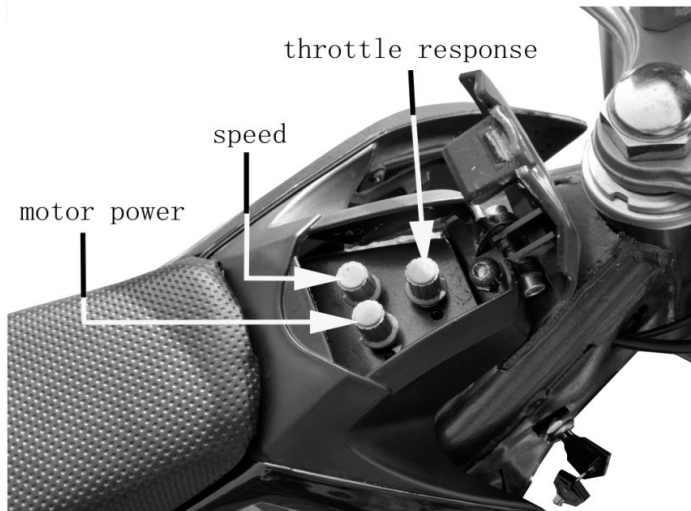

The 3-function adjustable switch is located under a plastic cover which is in the front of seat ( see above picture).

There are 3 letters standing for the different functions as follows,

**R:** Throttle response is adjustable from 0.2S to 1S in clockwise rotation

**S:** Top speed is adjustable from 8KM /H to 28KM/H in clockwise rotation

**P:** Motor power output is adjustable from 10A to 30A ( or 35A ) in clockwise rotation

### ● HAND DRIVE CONTROLS

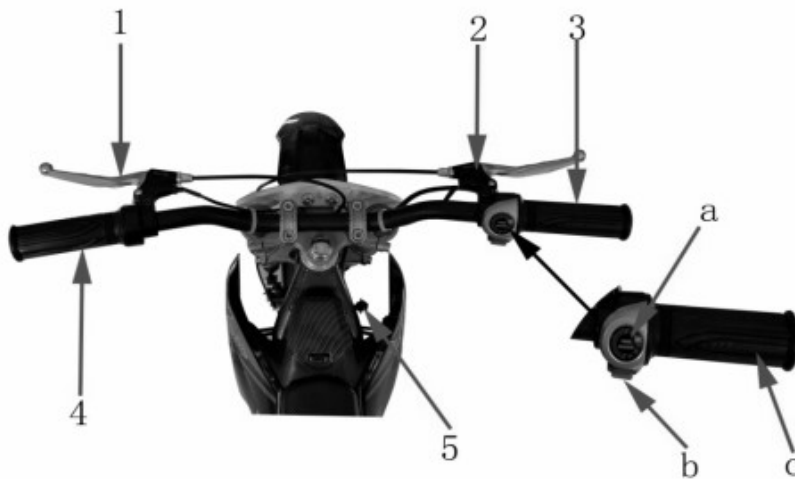

1. Rear brake lever

2. Front brake lever

3. Throttle& voltmeter assy.

4. Left grip

5. Ignition key switch

a : Voltmeter (coulombmeter) / b :safety ON/OFF switch / C:throttle grip

## MAIN PARTS



- 1.Splintage
- 2.number plate
- 3.front mudguard
- 4.Fork
- 5.front wheel & tire
- 6.frame bottom cover
- 7.front-right plastic
- 8.main frame
- 9.frame right cover
- 10.swing arm
- 11.riven sprocket
- 12.chain cover
- 13.rear wheel & tire
- 14.rear shock absorber
- 15.rear-right plastic
- 16.tail plastic
- 17.Seat
- 18.Tank
- 19.Handlebar



- 20.brake disc
- 21.front brake caliper
- 22.front-left plastic
- 23.frame right cover
- 24.motor
- 25.side stand
- 26.rear brake caliper
- 27.rear-left plastic

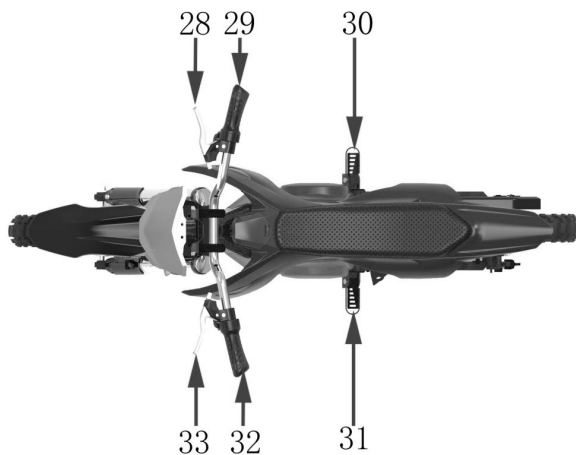

- 28.front brake lever
- 29.Throttle
- 30.footrest R
- 31.footrest L
- 32.left grip
- 33.rear brake lever



## **BEFORE YOU BEGIN**

Remove contents from box. Remove the foam separators that protect the components from damage during shipping. Inspect the contents of the box for scratches in the paint, dents or kinked cables that may occur during shipping. Because the product was 85 percent assembled and packed at the factory, there should not be any problems, even if the box has a few scars or dents.

**MAKE SURE KEY SWITCHES IS TURNED “ OFF” BEFORE CONDUCTING ANY PROCEDURES.**

### **Estimated Assembly and Set-Up Time**

We recommend assembly by an adult with experience in motorbike or bicycle mechanics.

Allow up to 30-40 minutes for assembly.

Allow up to 10 hours for initial charge.

### **Required Tools**

Some tools may be supplied; however, we recommend the use of mechanic's grade tools. Use the supplied tools only as a last resort.

The list of tool required is as follows

- Open end wrench 12mm / 14mm/ 17mm
- Allen wrench 5mm / 6mm

### **Front wheel assembly:**

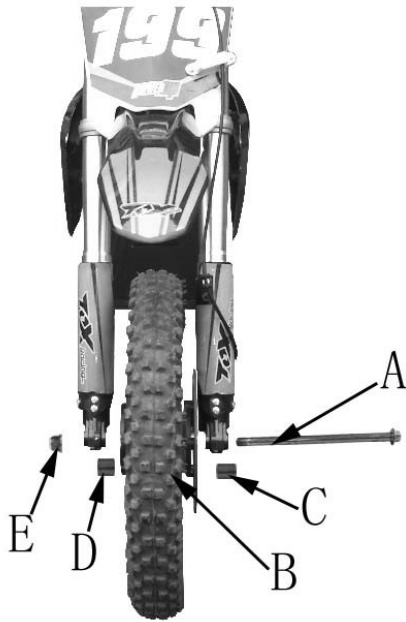

1. Mount the wheel axle (A) through the left fork and insert the spacer (C) / the wheel (B) / spacer (D) in sequence, then make the axle through the right fork.

2. Fix the nut (E) and tighten it with the open end wrench 14mm and 17mm.

A: wheel axle M12\*1.25\*205 x1

B: wheel x1

C: spacer  $\Phi 12*20*27$  x1

D: spacer  $\Phi 12*20*23$  x1

E: self lock nut M12\*1.25 x1

## Handlebar assembly

**Caution: Failure to properly adjust and tighten the bolts that affix the handlebar can cause you lose control and crash.**



1. Place the handlebar (D) onto the holder (C), cover the clamps (B).
2. Install the 4pcs bolts (A) into the clamps (B), make the handlebar in the upright and vertical position, tighten all the bolts (A) securely with 6mm allen wrench.

A: bolt M8\*20 x4  
B: handlebar clamp x2  
C: handlebar holder x2  
D: handlebar

## Rear shock absorber assembly:

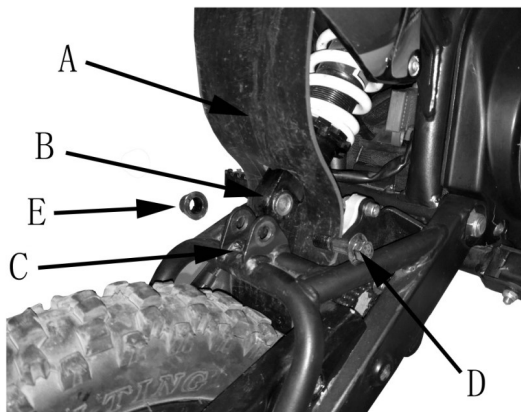

1. Put the rear shock absorber (B) into the rear mudguard (A).
2. Align the shock (B) mounting hole to the shackle joint hole on swing arm (C), fix the bolt (D) and nut (E) and tighten it with the open end wrench 12mm and 14mm.

A: rear mudguard x1  
B: rear shock absorber x1  
C: swing arm x1  
D: bolt M10\*1.5\*40 x1  
E: lock nut M10\*1.5 x1

## Rear mudguard assembly

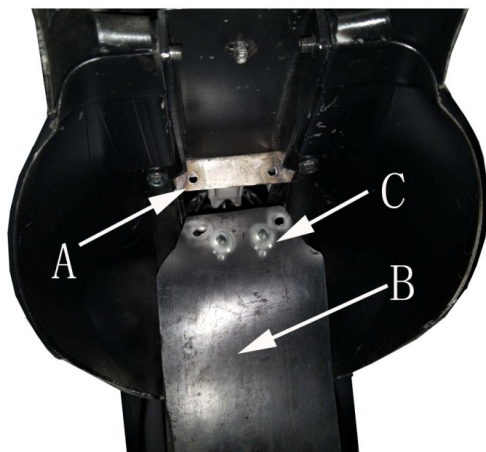

1. Align the mudguard (B) mounting 2 holes to the bracket under the seat, and fix the bolt (C)
2. Tighten the bolt with the allen wrench 5mm.

A: bracket  
B: rear mudguard  
C: bolt M6x12

## Front brake assembly

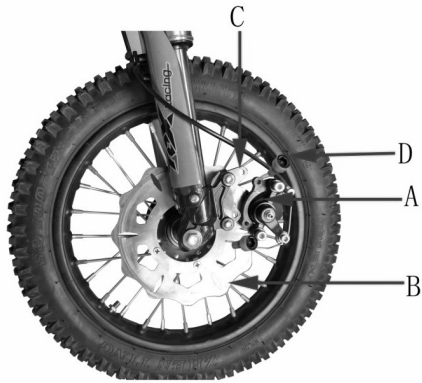

1. Place the brake disc (B) into the brake caliper (A), align the bracket (C) hole to the caliper (A) mounting hole.

2. Fix the bolt (D) and tighten it with the allen wrench 5mm.

A: brake caliper x1

B: brake disc x1

C: bracket x1

D: bolt M6\*12 x2

## Front mudguard assembly



1. Place the front mudguard (A) under the down splintage (B) and align the mudguard mounting 3 hole to the splintage holes.

2. Fix the 3pcs bolt (C) and tighten them with the allen wrench 6mm

A: front mudguard x1

B: down splintage x1

C: bolt M6\*16 x3

## Number plate assembly

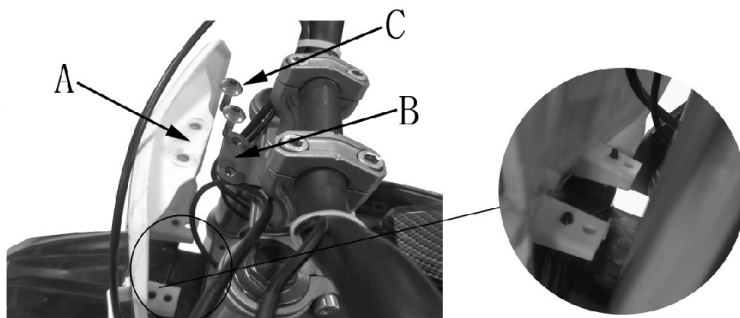

1. Align & Insert the plate(A) bottom 2 holes to the pegs on the front mudguard.

2. Align the plate(A) top 2 holes to the bracket (B) mounting holes which is attached to the upper splintage, fix the 2 bolts(C) and tighten with the allen wrench 5mm.

A: number plate x1 B: bracket x1 C: bolt M6\*12 x 2

## Fuse assembly

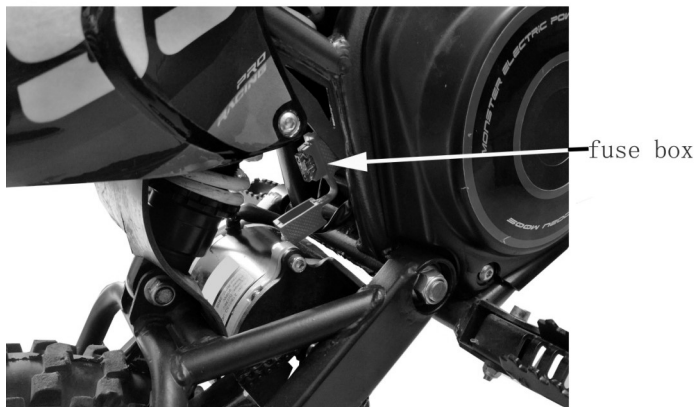

- 1.The fuse box is attached to the right side of frame, above the motor.
- 2.Open the fuse box cover, insert the fuse which is packed in the tool box,then close the cover.

## INFLATING THE TIRES



**NOTE:** The tires are inflated when shipped, but they invariably lose some pressure between the point of manufacturing and your purchase. Always inflate the tires to the correct PSI before first time use.

**Please read the specification sheet to get the information of tire pressure.**

Using a bicycle-style tire pump to inflate the tire to the PSI indicated on the sidewall of the tire.

**Note:** The pressurized air supplies found at gasoline stations are designed to inflate high-volume automobile tires. If you decide to use such an air supply to inflate your tires, first make sure the pressure gauge is working, then use very short bursts to inflate to the correct PSI. If you inadvertently over-inflate the tire, release the excess pressure immediately.

### Important information of use guider for tire

**Note:** Tire is the only contact between the vehicle to the road, the safety of various driving activity depends on the small area of tire where contact with the road. Therefore, it is very important to keep the tire in good condition any time and use the correct size and standard tire to replace the old ones.

**Guide:**

#### Tire assembly and disassembly

It is strongly recommended that the tire assembly and disassembly should be done by an authorized technician with necessary skills.

### **Tire inflating pressure**

It is very important to keep the tire in proper pressure and check the tire pressure before use. The inflating should be done while the tire is cold.

### **Tire maintenance**

Tire tread depth should be checked regularly. (Shallower tread means less grip of tire). You must stop to use the vehicle if the tire is pierced, disassemble the tire and check it carefully. Tire maintenance should be done by an authorized technician. Tire should be replaced immediately when it is distorted or damaged.

### **Tire replacement**

It is important to use the correct size and standard tire as per our specification (see details in technical specification sheet)

Don't use the used tire if you are not sure its previous service condition.

### **Tire aging**

Tire aging is unavoidable even the tire is not ever used or just used a few times. Tire aging is mainly reflected in the cracked section on side of tire and tire tread, sometimes the tire is distorted as well. The used and aged tire should be checked and confirmed if it is ok to use again by an authorized technician

## **BEFORE RIDING**

### **Charging the Battery**

Your electric motor bike may not have a fully charged battery; therefore it is a good idea to charge the battery prior to use.

- Initial charge time: 10 hours depending on level of depletion
- Run time: up to 30 minutes of continuous ride time at MAX speed, run time may vary depending on riding conditions.
- Average battery life: 120 charge/discharge cycles. To ensure long battery life, do not store the batteries in temperature above 75° or below -10° F
- Recharge time: *Always* remember to turn the power switch off and recharge for at least 6 hours after each use. When vehicle is not in regular use, recharge battery at least once a month until normal use is resumed. If you have left the power switch on or your product has not been charged for a long period of time the battery may reach a stage at which it will no longer hold a charge.

**WARNING:** rechargeable batteries are only to be charged under adult supervision. Always disconnect your electric motor bike from the charger before cleaning with liquid.

**NOTE:** Chargers have built-in over charge protection to prevent battery from being over charged. Charger will get warm during use, this is normal for some charges and is no cause for concern. If your charges does not get warm during use, it does not mean that it is not working.

The charger has a small window with LED to indicate the charge status. Red LED means the battery is in charging and Green LED means the battery is full charged. Chargers have built-in over-charge protection to prevent battery from being over-charged.

Be sure to properly align the groove on the charger input port with the corresponding socket on the vehicle and tighten threads; otherwise, no charging action will occur.

### Charge port location



Charge port is located at the left front side of frame ( see above picture)

### Charger

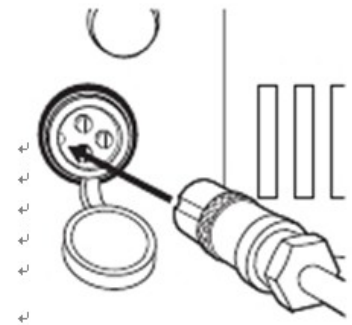
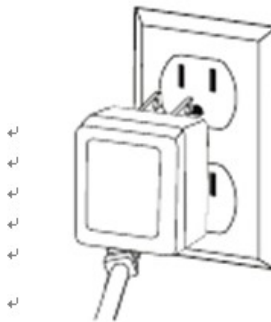
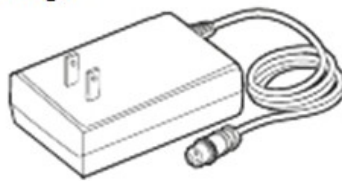

**Note:** Make sure power is turned **OFF** when unit is not in use. If the power switch is left on for an extended period of time, the battery may reach a stage at which it will no longer hold a charge.

1 Plug the charger into a wall outlet. If the lights on charger do not light up, check the power to the outlet. If necessary, try a different outlet.

2 Turn power **OFF** before charging. Plug the charger into the charge port to charge unit.

**Warning:** Failure to recharge the battery at least once a month may result in a battery that will no longer hold a charge.

## **SAFETY REMINDERS**

### **PRE-RIDE CHECKLIST**

#### **Loose Parts**

Check and secure all fasteners before every ride. Make sure steering stem clamp bolts are locked properly in place. There should not be any unusual rattles or sounds from loose parts or broken components. If you are not sure, ask an experienced mechanic to check.

#### **Brake**

Check the brake for proper function. When you squeeze the lever, the brake should provide positive braking action.

#### **Frame, Fork and Handlebars**

Check for cracks or broken connections. Although broken frames are rare, it is possible for an aggressive driver to bash into a curb or wall and wreck and bend or break a frame. Get in the habit of inspecting yours regularly.

#### **Tire Inflation**

Periodically inspect the tires for excess wear, and regularly check the tire pressure and re-inflate as necessary. If you get a flat tire, the inner tube can be patched or a new tube can be purchased from an authorized repair shop.

#### **Safety Gear**

Always wear proper protective equipment such as an approved safety helmet, elbow pads and kneepads. Always wear shoes (lace-up shoes with rubber soles), never drive barefooted or in sandals, and keep shoelaces tied and out of the way of the wheels, motor and drive system

### **ATTENTION**

We recommend checking all tightened parts after the first time use. Special attention should be paid to the following parts:

- Footrest
- Handlebar
- Engine sprockets (Racing version only)
- Shock absorber
- Engine bolts and nuts
- Rear sprocket
- Wheel



## REPAIR AND MAINTENANCE

### Fuse Replacement:

Warning : Turn key switch "OFF" before conducting any maintenance procedures

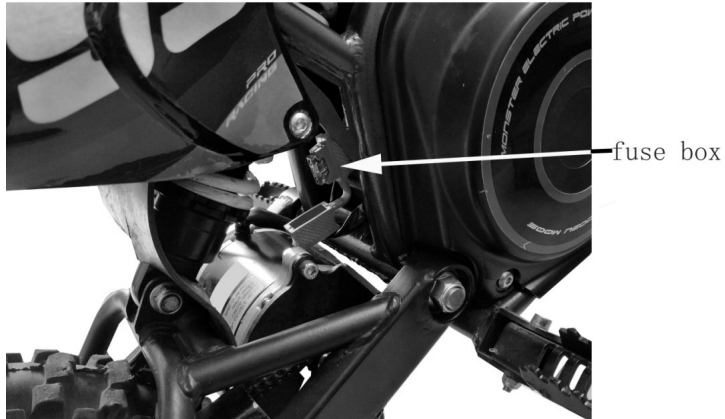

### **WARNING:**

To prevent shock, please follow below instructions accordingly and do not skip or combine any steps

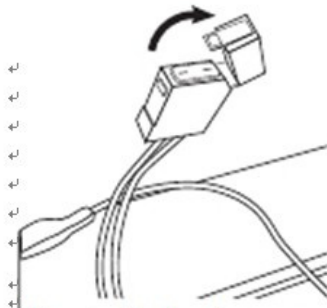

Locate the fuse box attached to the batteries. Open the fuse cover to expose the fuse.

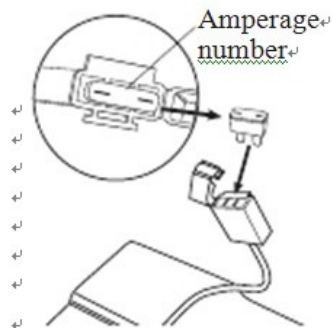

Remove the fuse and replace with a new one of equal amperage. Requires 30 amp fuse. Close the fuse cover and reattach the battery cover.



## Chain maintenance and adjustment:

1. Always keep the chain lubricated in order to reduce the chain wearing and ensure the longer chain life.
2. Checking the drive chain periodically and follow the next steps to adjust the chain to make it work properly.

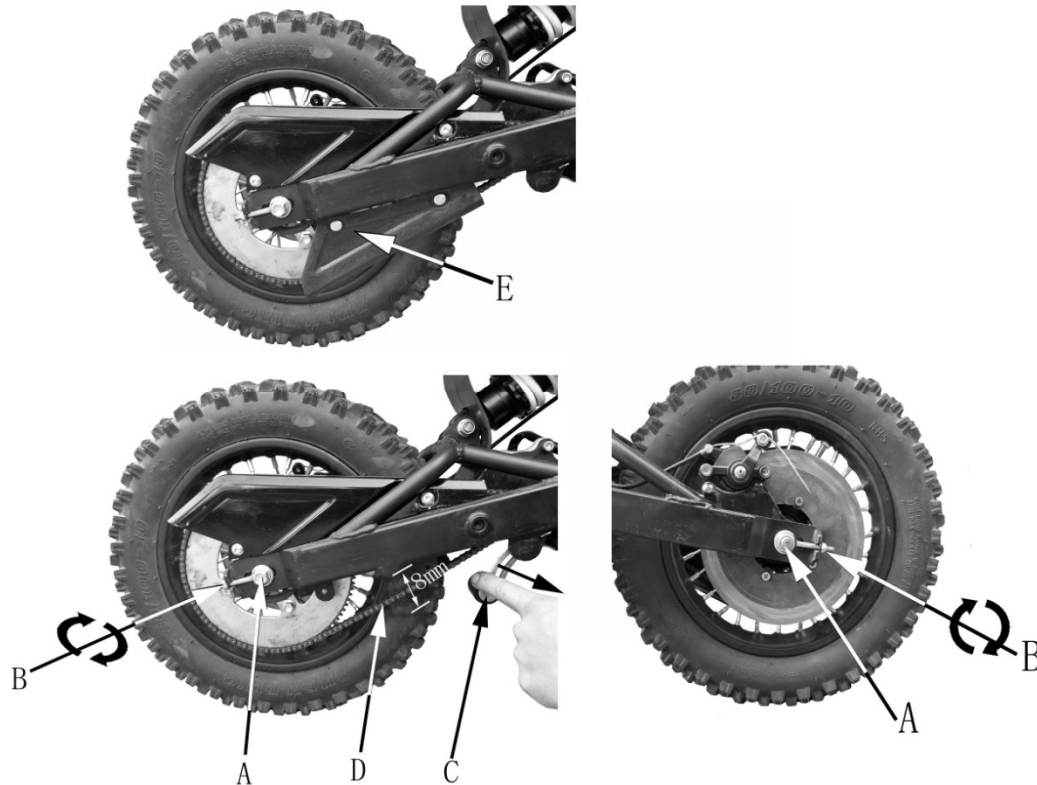

- **Step 1:** Remove the chain cover ( E ) with the allen wrench 4mm.
- **Step 2:** Loosen the nut on the wheel axle ( A ) with the open end wrench 14mm and 17mm, adjust the chain adjuster ( B ) to make the chain tension in good condition while the freely moving gap is  $\leq 8\text{mm}$  ( without the chain tensioner attaching on the chain )
- **Step 3:** Lock all the nuts and screws, check the wheel alignment and then re-attach the chain cover.

## Brake adjustment:



### Step 1:

To adjust the brake tension, thread the brake lever adjuster in or out 1/4 or 1/2 turn until the required brake adjustments is attained.

Most of brake adjustments are complete at this step, if the brake still need the further adjustment,

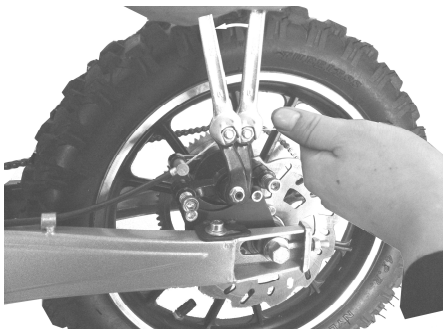

### Step 2:

With 10mm open spanner, loose the brake cable and adjust the brake caliper arm to make the cable length >30mm from arm to the pillar.

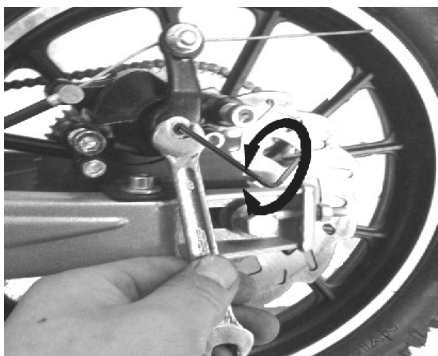

### Step 3:

With 8mm open spanner to loose the nut of friction pad, and with 2.5mm allen wrench to adjust the inner screw for friction pad.

## Brake pads check and replacement:

To check the wear of front and rear brake pads **A**, simply inspect the brakes calipers as shown in the below picture.

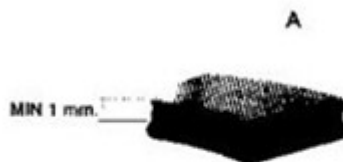

The thickness of the lining on the ends of the four pads should never be less than 1mm.

Should the lining be thinner, immediately replace the brake pads.

**We recommend having the brake pads replaced by an authorized dealer.**

## Warning:

The brake is capable of causing the electric bike to skid the tire throwing an unsuspecting rider. Practice in an open area free from obstacles until you are familiar with the brake function. Avoid skidding to stop as this can cause you lose control or damage the rear tire.

## Testing the Brakes

To use the brake, squeeze the lever to increase the pressure on the brake. The brake lever is fitted with a cable adjuster to compensate for cable stretch and/or to fine-tune the lever movement to brake engagement. If brake is not engaging properly, follow instructions for adjusting the brakes.

## Chain and sprocket

The chain will typically have a “loose spot” and “tight spot” corresponding with a particular sprocket rotational position. This is normal and common to all chain-driven products due to run-out to tolerance of the free wheel and sprocket. The chain should be adjusted to the ideal tension with chain in the tightest spot.

Proper chain alignment must be maintained. The wheel must not be skewed, if the chain is noisy or rough running, check the lubrication, tension and alignment of sprockets, in that order.

### Warning:

**To avoid a pinch or injury, keep fingers away from moving sprockets and chain.**

## Battery disposal



CONTAINS SEALED NON-SPILLABLE LEAD BATTERIES.  
BATTERIES MUST BE RECYCLED.,

**Disposal:** Your products use sealed lead-acid batteries which must be recycled or disposed of in an environmentally sound manner. Do not dispose of a lead-acid battery in a fire. The battery may explode or lead. Do not dispose of a lead-acid battery in your regular household trash. The incineration, land filling or mixing of sealed lead-acid batteries with household is prohibited by law in most areas. Return exhausted batteries to a federal or state approved lead-acid battery recycler or a local seller of automotive batteries.

### Warning:

If a battery leak develop, avoid contact with the leaking acid and place the damaged battery in a plastic bag. Refer to the disposal instructions above, if acid comes into contact with skin or eyes, flush with cool water for at least 15 minutes and contact a physician.

### Warning:

Battery posts, terminals and related accessories contain lead and lead compounds.

**Wash hands after handling.**

## Charger

The charger supplied with the bike should be regularly examined for damage to the cord, plug, enclosure and other parts, and, in the event of such damage, the bike must not be charged until it has been repaired or replaced.

**USE ONLY WITH THE RECOMMENDED CHARGER**

## TROUBLESHOOTING GUIDE

Problem	Possible cause	Solution
Vehicle does not run.	Undercharged battery.	Charge the battery. A new battery should have been charged for at least 12 hours before using the vehicle for the first time and up to 8 hours after each subsequent use.
		Check all connectors. Make sure the charger connector is tightly plugged into the charging port, and that the charger is plugged into the wall.
		Make sure power flow to wall outlet is on.
	Charger is not working.	You may check to see if your charger is working by using a volt meter or asking the authorized service center to test your charger for you.
Vehicle was running but suddenly stopped.	Loose wires or connectors.	Check all wires and connectors to make sure they are tight.
	Burned-out fuse.	The fuse will burn out and automatically shut off the power if the motor is overloaded.
		An excessive overload could cause the motor to overheat. Refer to replacing the fuse instructions of this manual. Correct the conditions that caused the fuse to burn out and avoid repeatedly burning out fuse.
	Motor or electrical switch damage.	Contact the authorized service center for diagnosis and repair.
Short run time less than 15 minutes per charge	Undercharged battery	Charge the battery. A new battery should have been charged for at least 12 hours before using the vehicle for the first time and up to 8 hours after each subsequent use.
		Check all wires and connectors. Make sure the battery connector is tightly plugged into the charger connector, and that the charger is plugged into the wall.
		Make sure power flow to the wall outlet is on.
	Battery is old and will not accept full charge.	Even with proper care, a rechargeable battery does not last forever. Average battery life is 1 to 2 years depending on vehicle use and conditions. Replace only with a replacement battery.
	Brakes are not adjusted properly	Refer to brake adjustment instructions.

Vehicle runs Sluggishly.	Driving conditions are too stressful.	Use only on solid, flat clean and dry Surfaces such as pavement or level ground.
	Tires are not properly Inflated.	The tires are inflated when shipped, but They invariably will lose some pressure Between the point of manufacturing and your purchase. Refer to tire instructions to properly inflate tires.
	Vehicle is overloaded.	Make sure you do not overload the vehicle by allowing more than one rider at one time, exceeding the maximum weight limit, going up too steep a hill or towing objects behind the vehicle. If the vehicle is overheated, the temperature circuit protector will slow motor down and if the condition continues, will shut off power to the motor. Correct the driving conditions that caused the overheating, wait 5-10 minutes and then resume riding. Avoid repeatedly overheating the unit.
Sometimes the vehicle doesn't run, but other times it does.	Loose wires or connectors	Check all wires around the motors and all connectors to make sure they are tight.
	Motor or electrical Switch damage.	Contact the authorized service center for diagnosis and repair.
Charger gets warm During use	Normal response to Charger use	No action required. This is normal for some Chargers and is no cause for concern. If your charger dose not get warm during use, it does not mean that it is not working properly.
Vehicle does not Stop when applying the brake.	Brakes are not adjusted properly	Refer to brake instructions to properly adjust Brakes.
Vehicle makes loud noises or grinding sounds	Chain is too dry	Apply a lubricant to the chain.

# CIRCUIT DIAGRAM

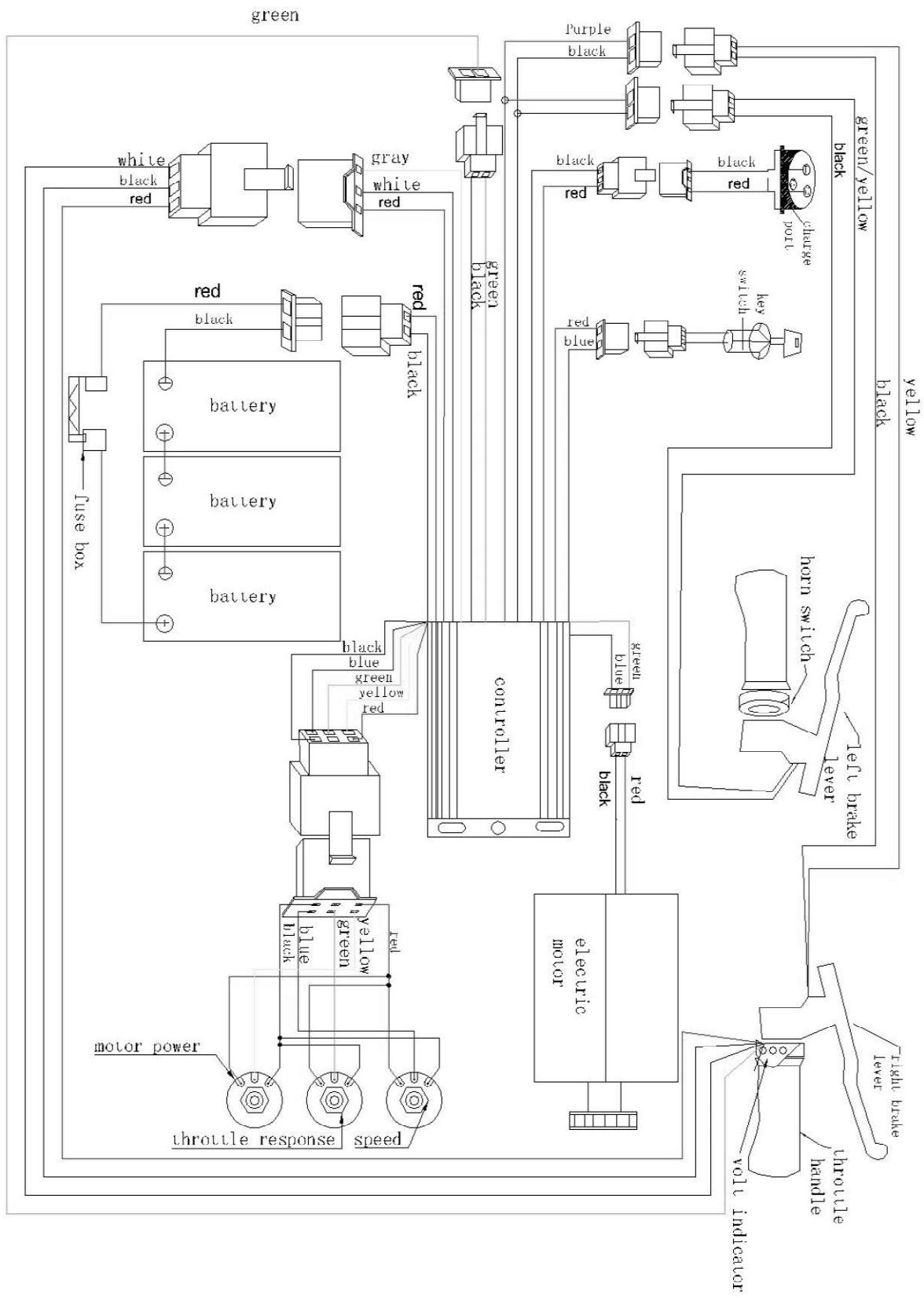



Please read the owner's manual before riding.



Never operate this vehicle if you are under age 13



Never use the vehicle on public road. OFF ROAD use only.



Never ride with a passenger



Always use an approved helmet and protective gear



NEVER use with drugs or alcohol



Cold tire pressure.

